



Reduce heating costs by up to **75%**



ENERGY EFFICIENT



CORROSION RESISTANT



SMART CONTROL TIMER



ECO-FRIENDLY REFRIGERANT

The most energy efficient heater

Air sourced heat pumps are the most energy efficient and cost-effective method of heating your spa or pool water. When compared to gas or electric heaters, a heat pump uses a tiny portion of energy to generate the same amount of heat output. By using refrigeration technology a heat pump only requires a small amount of energy to run a fan motor and compressor, yet can output over five times more energy in heat compared to what it consumes in electricity.

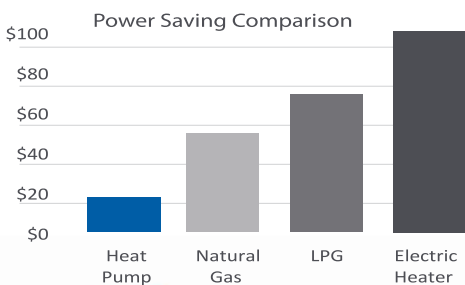

This means a Powersmart heat pump will use around 75% less energy than a standard electric spa heater and 55% less energy than natural gas. The massive saving in electricity allows you to cost effectively keep your spa or swim spa at temperature and ready to use all year round, or cost effectively extend the swimming season of your swimming pool.

Why pay your energy provider for a heat pump you'll never receive

Without a heat pump installed you will be paying your energy provider 75% more than you should to heat your spa or pool. Having a heat pump installed offers such a massive reduction in electricity cost, these savings will quickly recover your investment cost. Put simply, if you don't have a heat pump installed your increased outgoing electricity costs will have paid for the cost of a heat pump that you will never receive.

Eco-friendly refrigerant

Unlike other refrigerants R410A does not cause ozone depletion and achieves higher performance with reduced power usage.

Benefits of low power consumption

Traditionally spas with low amperage power supplies have been restricted to a 3kW electric element and had insufficient power available for heating when a jet pump is running. However a Powersmart heat pump consumes such little power you have the added benefits of reduced heating times due to the larger 6.0/8.3/14.0kW heating output, and you can spa for longer because there is sufficient power available to run the heat pump whilst a jet pump is running.

Ideal for heating

Spas, swim spas, plunge pools and swimming pools.



CORROSION RESISTANT

Corrosion resistant plastic enclosure with superior UV resistance and a modern design style ensures the heat pump is aesthetically pleasing for your backyard and remains that way over time. By producing the heat exchanger coil from Titanium and exchange tank from PVC we maximise corrosion resistance to commonly used spa and pool chemicals such as lithium, bromine, ozone, iodine, salt, chlorine and baquacil.

SMART CONTROL TIMER

The plastic cabinet has been sensibly engineered to locate the IPX5 grade smart control touch pad in a convenient position, angled on the lid of the heat pump. This ensures the process of checking the temperature and adjusting settings is comfortable and easy to read without needing to crouch or bend down to the side of the unit. The smart control micro-processor manages heat only, cool only, or automatic temperature modes, onboard diagnostic information, self-diagnosis error codes and features two sleep timers so the user can program sleep periods to take advantage of off-peak power periods or to prevent operation during certain times of day.

ALL SEASONS OPERATION

The Powersmart heat pump range has automatic defrost protection allowing operation throughout all seasons even in low ambient temperatures (<5°C). If the environmental temperature is too low and the air is very humid and cold, automatic defrost control will be activated when necessary to maintain optimal heat pump performance. The Powersmart heat pumps also feature an electronic expansion valve (EEV) to control the refrigerant flow accurately according to ambient temperature variation, making the energy efficiency 10%-30% higher.

SPECIFICATIONS

POWER	SHP-60P	SHP-80P	SHP-140P	SHP-170P	SHP-190P
Input Voltage	220-240V AC	220-240V AC	220-240V AC	220-240V AC	220-240V AC
Hertz / Phase	50Hz / 1	50Hz / 1	50Hz / 1	50Hz / 1	50Hz / 1
Power Input	1.1kW	1.5kW	2.6kW	3.1kW	3.6kW
Current	5.3A	7.2A	12.8A	15A	17A

HEATING OUTPUT

Heating Capacity - A24°C / W27°C*	6.0kW	8.3kW	14.0kW	17.0kW	19.5kW
COP - A24°C / W27°C	5.5	5.5	5.5	5.5	5.5
Heating Capacity - A15°C / W27°C	4.6kW	6.7kW	11.9kW	13.6kW	17kW
COP - A15°C / W27°C	4.6	4.6	4.6	4.6	4.6

COOLING OUTPUT

Cooling Capacity - A32°C / W27°C	4.3kW	5.8kW	9.7kW	11.5kW	14.5kW
EER - A32°C / W27°C	3.6	3.6	3.6	3.6	3.6

COMPONENTS

Compressor Style	Rotary	Rotary	Rotary	Rotary	Rotary
Compressor Brand	Panasonic	Panasonic	Panasonic	Copeland	Copeland
Heat Exchanger	Titanium / PVC	Titanium / PVC	Titanium / PVC	Titanium / PVC	Titanium / PVC
Expansion Valve	Electronic (EEV)	Electronic (EEV)	Electronic (EEV)	Electronic (EEV)	Electronic (EEV)
Defrost Element	Electric	Electric	Electric	Electric	Electric
Refrigerant	R410A	R410A	R410A	R410A	R410A

MECHANICAL

Water Connection	40mm PVC	40mm PVC	40mm PVC	50mm PVC	50mm PVC
Operating Temperature Range	0°C - 40°C	0°C - 40°C	0°C - 40°C	0°C - 40°C	0°C - 40°C
Fan Direction	Horizontal	Horizontal	Horizontal	Horizontal	Horizontal
Fan Rotate Speed - RPM	850	850	850	900	900
Noise - dB(A)	48	49	52	53	54
Water Flow Volume - m3/hr	4	5	8	9	10
Net Unit Size - L/W/H (mm)	985x360x620	985x360x620	1120x480x840	1120x480x840	1120x480x840
Carton Size - L/W/H (mm)	1045x455x650	1045x455x650	1200x530x890	1200x530x890	1200x530x890
Net / Gross Weight - kg	54 / 62	64 / 72	90 / 100	98 / 111	106 / 119

* A = ambient air temperature W = water temperature

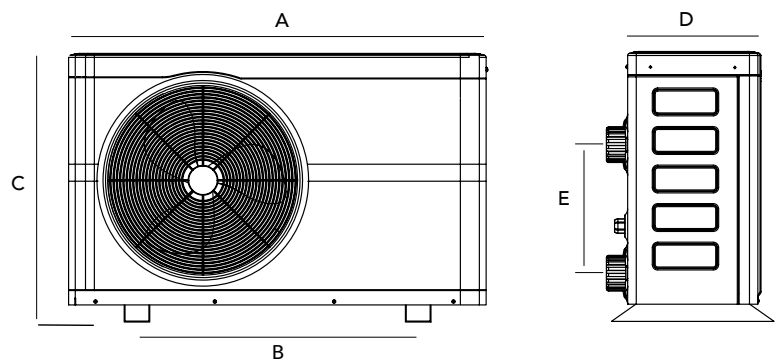

	SHP-60P	SHP-80P	SHP-140P	SHP-170P	SHP-190P
A	985mm	985mm	1120mm	1120mm	1120mm
B	615mm	615mm	725mm	725mm	725mm
C	620mm	620mm	840mm	840mm	840mm
D	360mm	360mm	480mm	480mm	480mm
E	300mm	300mm	400mm	400mm	400mm

